

Backdraft Damper • 7½" Deep • Single Thickness Blade • Round Frame • Aluminum • -35°F to 180°F Temperature

Standard Construction and Materials

- FRAME:** .080" thk. (nominal) aluminum, 7½" deep.
- BLADE:** .080" thk. (nominal) aluminum, reinforced for frames over 18" dia.
- AXLE:** ½" dia. aluminum, continuous.
- BEARINGS:** Flange oilite bronze.
- SEALS:** On frame, ¼" thick closed cell neoprene. Temperature range is -35°F to 180°F.
- FINISH:** Mill.

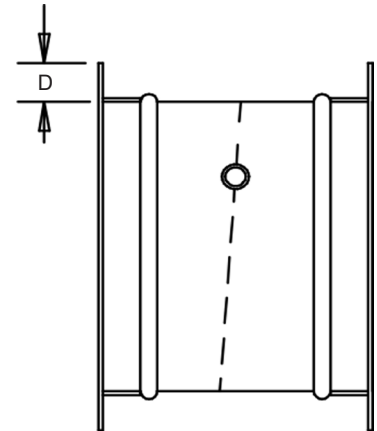

Equal leg angles are available. They are welded to frames at intermittent spacing and caulked between welds. Flange Height "D" varies with damper diameter.

Options

Counter balance - mounted to blade or installed on extended shaft.

Notes

1. ¼" nominal deduction will be made to the opening size given.
2. Please contact the factory for damper sizes larger than 36" diameter.
3. When ordering a counter balance, please specify type: assist or resist opening.
4. Damper sizes of 12" dia. and less shall have a counter balance located on an extended shaft only.
5. To calculate approximate shipping weight (lbs./in.), use following formula:
 Damper Circumference (Diameter [in.] × 3.141) × 0.5

Damper Sizes

Minimum Size	Maximum Size
4" O.D.	36" O.D.

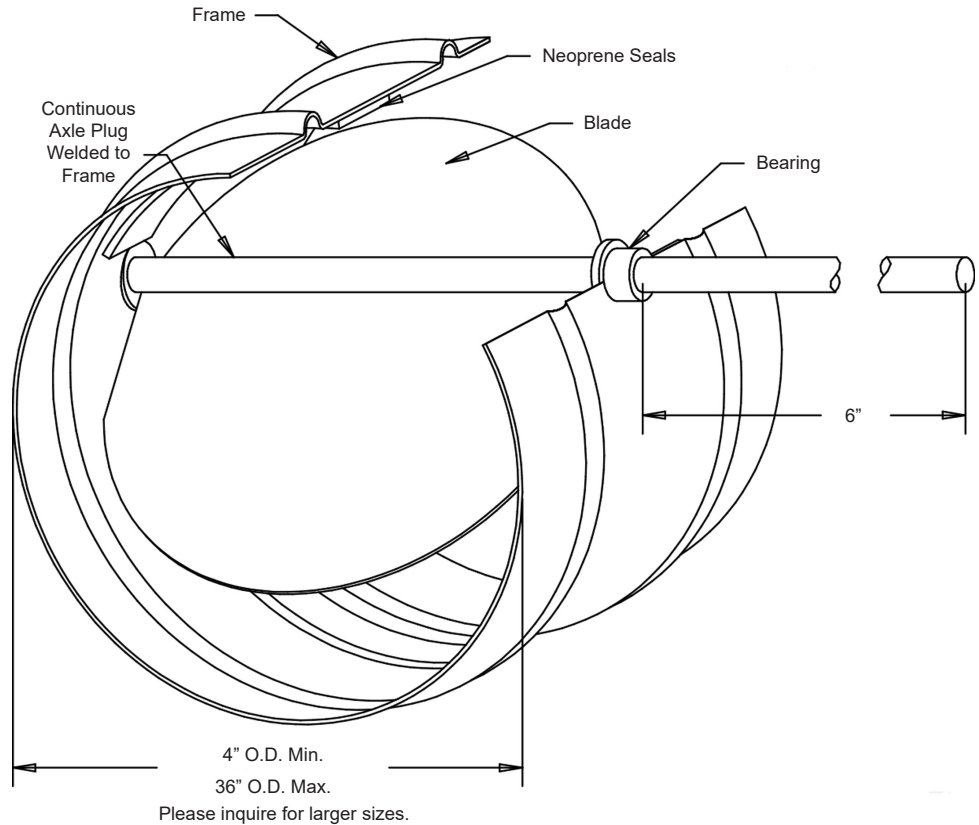

Item #	Qty	Damper Size O.D.	Assist Counter Balance	Resist	Remarks		
Arch. / Eng.:			EDR:		ECN:		Job:
Contractor:							
Project:			Date:		DWN:		DWG:

In the interest of product development, Cesco Products reserves the right to make changes without notice.



450 Riverside Dr • Wyalusing PA, 18853
 Phone: 570-746-1888 • Fax: 570-746-9286
 www.cescoproducts.com